

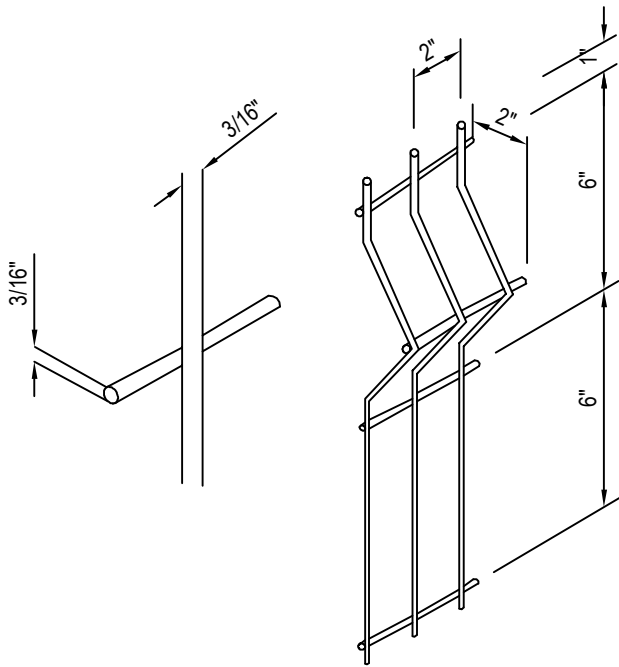

AMETCO MANUFACTURING CORPORATION  
 4326 HAMANN PARKWAY P.O. BOX 1210  
 WILLOUGHBY, OH 44096  
 TOLL FREE: 1-800-321-7042  
 PHONE: (440) 951-4300  
 FAX: (440) 951-2542  
 www.ametco.com

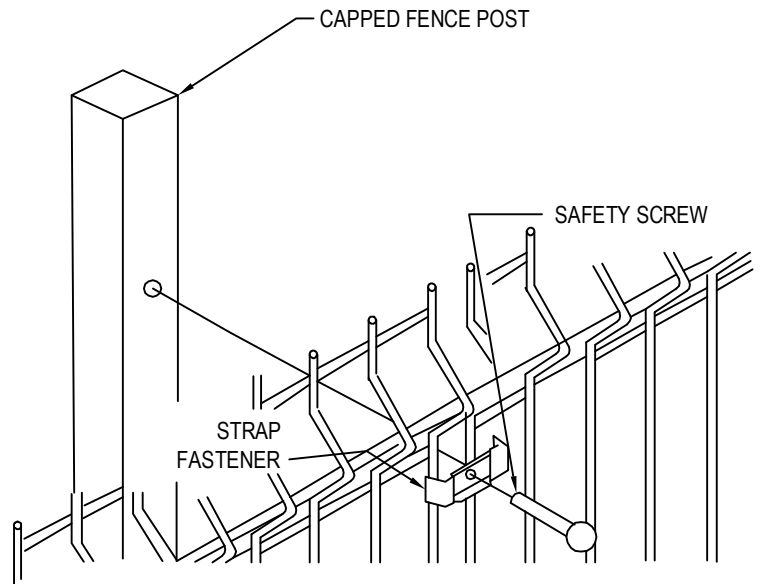

POST

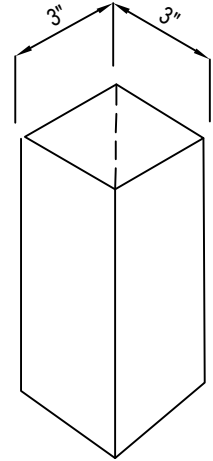

**NOTES:**

1. INSTALLATION TO BE COMPLETED IN ACCORDANCE WITH MANUFACTURER'S SPECIFICATIONS.
2. DO NOT SCALE DRAWING.
3. THIS DRAWING IS INTENDED FOR USE BY ARCHITECTS, ENGINEERS, CONTRACTORS, CONSULTANTS AND DESIGN PROFESSIONALS FOR PLANNING PURPOSES ONLY. THIS DRAWING MAY NOT BE USED FOR CONSTRUCTION.
4. ALL INFORMATION CONTAINED HEREIN WAS CURRENT AT THE TIME OF DEVELOPMENT BUT MUST BE REVIEWED AND APPROVED BY THE PRODUCT MANUFACTURER TO BE CONSIDERED ACCURATE.
5. CONTRACTOR'S NOTE: FOR PRODUCT AND COMPANY INFORMATION VISIT [www.CADdetails.com/info](http://www.CADdetails.com/info) AND ENTER REFERENCE NUMBER 048-062.

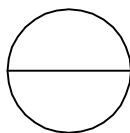

**AMOPANEL PANELS**

2" x 6" MESH, BASIC SECURITY