

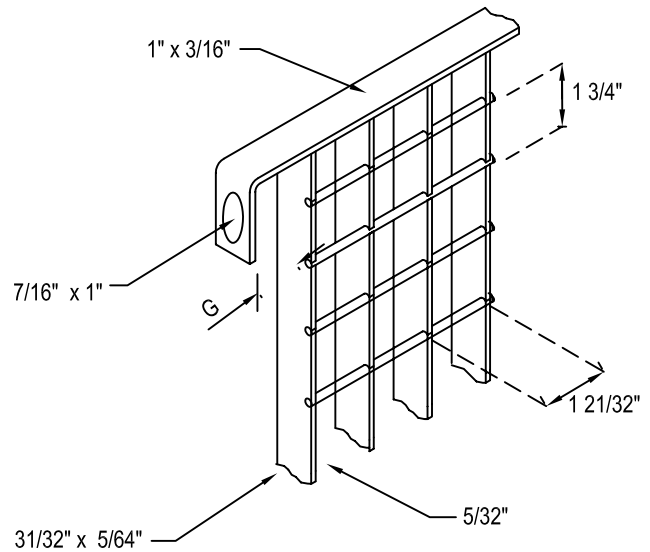

AMETCO MANUFACTURING CORPORATION
 4326 HAMANN PARKWAY P.O. BOX 1210
 WILLOUGHBY, OHIO 44096
 800-321-7042 TOLL FREE
 PHONE: (440) 951-4300
 FAX: (440) 951-2542
 www.ametco.com

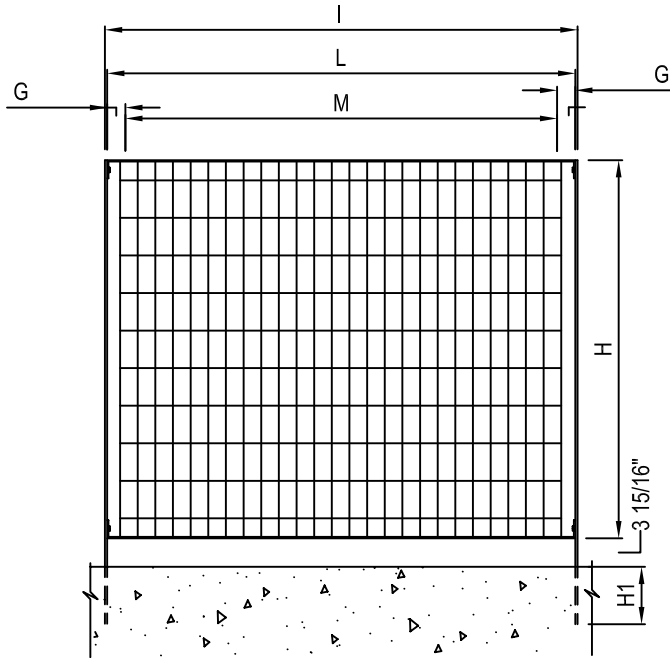

H	PANEL HEIGHT	UP TO 144" HIGH
H1	ANCHORE LENGTH*	8" UP TO 60" HIGH 10" UP TO 80" HIGH 12" UP TO 96" HIGH 18" OVER 96" HIGH
I	POST WIDTH	76-1/2" MAXIMUM
L	PANEL WIDTH	76-3/16" MAXIMUM
M	WIDTH OF GRILLE	72-11/16" MAXIMUM
G	LUG PROJECTION	1-3/4" MAXIMUM
	POST SIZE*	2-1/2" X 5/16" FLAT BAR UP TO 60" HIGH 3-1/2" X 5/16" FLAT BAR UP TO 96" HIGH 2" X 2" SQUARE TUBE OVER 96" HIGH
*FINAL DETERMINATION OF ANCHORE LENGTH AND POST SIZE IS BASED ON PANEL SIZE, SITE CONDITIONS AND DESIGN CONSIDERATION.		

NOTES:

1. INSTALLATION TO BE COMPLETED IN ACCORDANCE WITH MANUFACTURER'S SPECIFICATIONS.
2. DO NOT SCALE DRAWINGS.

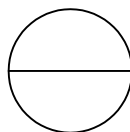

SHIELD DESIGN

1-21/32" x 1-3/4" MESH